

# KING

*Motorsports*



*Honda/Acura Performance*

## Table of Contents

Page	1	Introduction
	2	Mugen Sports Dampers, Tokico Struts
	3	Mugen Stabilizer Bars, Eibach Springs, Mugen Hard Rubber Bushings
	4	KMS Upper Stress Bars, Carbon Metallic Brakes, Motul Brake Fluid
	5	Stainless Steel Brake Lines, Mugen Road Wheels
	6	Mugen Sports Exhausts, HKS Exhaust
	7	Mugen Exhaust Manifolds
	8	Mikuni Sidedraft Kit, 34/34 Weber Conversion, Mugen Intake Manifolds
	9	K & N Air Filters, Power-Flow Air Filters
	10	Ultra Ignition Wires, KMS at the Races
	11	What is Mugen?
	12	KMS Racing
	13	KMS Engine Development, Adjustable Cam Gear
	14	Mugen Camshafts, KMS Camshafts, Mugen Valve Springs
	15	Mugen Polished Valves, KMS Forged Pistons, Mugen Big Bore Piston Kits
	16	CRX High Compression Pistons, Forged Steel Rods, Mugen Head Gaskets, Mugen Engine Bearings
	17	Mugen Oil Cooler Adapter, Mugen Clutches, Lite Flywheels
	18	CRX/Civic High Performance Clutch/Flywheel, Mugen Limited Slip, Mugen Close Ratio Gears, 4.90 Final Drive
	19	Mugen Steering Wheels, Mugen Rear Spoilers
	20	Mugen Body Kits
	21	Mugen Polo Shirts & Jackets, KMS T-Shirt & Sweat Shirts
	22	Mugen Decals, Emblems, Keychains
	23	Wolf Bras, Evolution III Car Covers, Honda Oil Filters
	24	Redline Oil, Mugen Formula 337 Oil Treatment, Autopower Roll Cage

### King Motorsports

105 East Main Street

Sullivan, WI 53178

Phone 414-593-2800 FAX 414-593-2627

© Copyright 1991, King Motorsports, Inc., Sullivan, Wisconsin

PHONE 414-593-2800  
FAX 414-593-2627



*Dear Honda Enthusiast:*

*I am sure you have heard the various sales pitches from the aftermarket Honda performance world. Our headers are faster, our floor mats are mottier and on and on... King Motorsports is not about sales pitches or hype, we do on the other hand, provide the parts you need to be a winner... end of story. Our track record over the past ten years offers substantial proof that King Motorsports is the undisputed leader in performance technology for your Honda or Acura.*

*King Motorsports is very proud to be chosen sole distributor for Mugen Co., Ltd. For those of you who are unaware of Mugen, some background. In 1973, Mugen Co., Ltd. President Hirotoshi Honda, son of Sirochiro Honda, founder of Honda Motor Co., Ltd., applied his superior engine tuning capabilities to a 1200 cc Honda engine. Hirotoshi and his then small company either modified or re-made every component in this engine. It became a wildly successful race engine and won the formula FJ 1300 Racing series in its very first season! The success also sparked Honda to return to racing and now Mugen and Honda work side by side in many racing projects. Since its humble beginnings in 1973 Mugen Co., Ltd. has grown into one of the most advanced racing development companies in the world. Mugen components and engines are dominant worldwide from Group A sedans, SCCA GT-3, IMSA RS to Formula 3 and 3000 and now the pinnacle of racing, Formula-One.*

## SUSPENSION

While the stock suspension of your Honda or Acura is entirely adequate for everyday driving, the demands of performance driving, autocrossing and racing require performance upgrades. Generally, changing the dampers or struts is the first step. If your car has over 30,000 miles on the stock dampers, the improvement you will feel is tremendous. The next step is to control body lean by upgrading stabilizer bars. To reduce understeer (common to front wheel drive) more rear roll stiffness is needed, and that is why KMS uses a larger stabilizer bar in the rear than in the front. Changing to a sport spring kit will lower your car's center of gravity and will reduce brake dive and squat under acceleration, and lastly for the competition driver, changing the suspension bushings maintains constant suspension geometry. There you have it, one of the finest handling cars you will ever have the pleasure of driving.

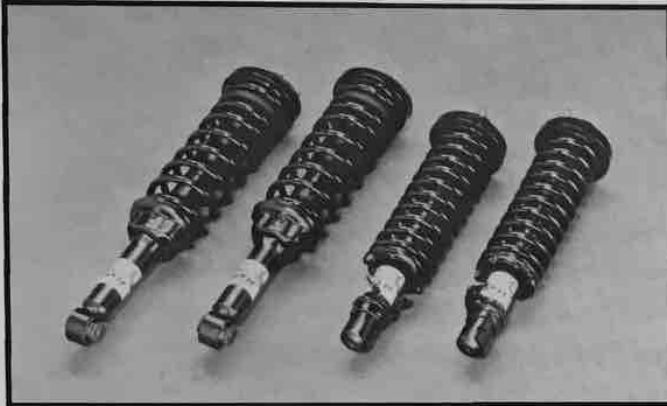

## MUGEN SPORTS DAMPERS

Mugen uses its close association with OEM supplier Showa, to design and construct these Sport Damper sets. Mugen Sports Damper sets are designed specifically for each application. You will immediately notice a firm, yet subtle ride which will eliminate the floatiness and uneasy feeling encountered with the stock dampers. Mugen supplies special, standard ride height springs so spring compressors are not necessary for installation, with the following damper sets:

CRX/Civic . . . . .	88-91	Accord . . . . .	86-89
Prelude . . . . .	83-87	Prelude . . . . .	88-91
Integra . . . . .	90-91		

### APPLICATION LIST - MUGEN SPORTS DAMPERS

CRX/Civic . . . . . 84-87	CRX/Civic . . . . . 88-91	Accord . . . . . 86-89	Integra . . . . . 90-91
Integra . . . . . 86-89	Prelude . . . . . 83-87	Prelude . . . . . 88-91	

## TOKICO GAS STRUTS

Tokico has become the leader in Gas strut technology. Tokico uses a twin tube design which offers two distinct advantages over a conventional monotube gas strut: low pressure and flexible valving. This combination allows the Tokico strut to have finer tuning capabilities over a wide range of speeds and deflections. In the real world this means impressive ride quality with immense gains in vehicle control. For those who wish added adjustability, Tokico offers the Illumina Strut which is externally adjustable, a big benefit for Autocross and performance driving. All Tokico struts are backed by a **lifetime guarantee**. If you're looking for a high-performance gas strut, Tokico offers unsurpassed performance.

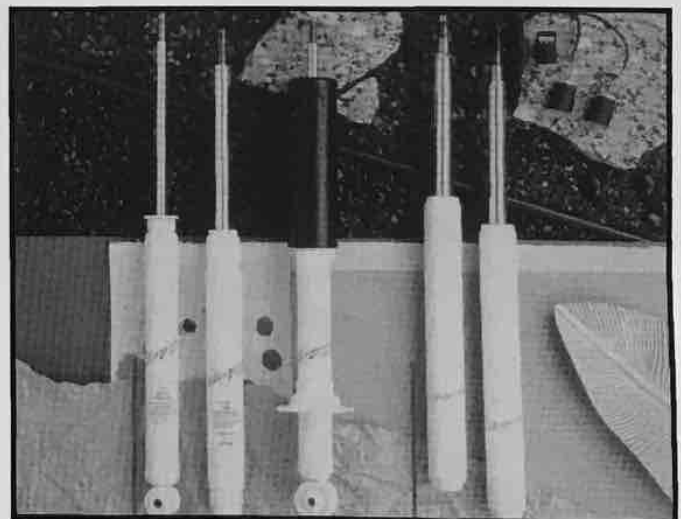

### APPLICATION LIST

Accord . . . . . 76-78	Civic . . . . . 80-83	CRX/Civic . . . . . 84-87*	Integra . . . . . 90-91*
Accord . . . . . 79-81	Legend 4 dr . . . . . 86-88	CRX/Civic . . . . . 88*	Prelude . . . . . 80-82
Accord . . . . . 82-85	Legend 4 dr . . . . . 89	CRX/Civic . . . . . 89-91*	Prelude . . . . . 83-87
Accord . . . . . 86-89	Legend Cpe . . . . . 87-89	Integra . . . . . 86-89*	Prelude . . . . . 88-91
Civic . . . . . 75-79			

\*Also available in Illumina Adjustable

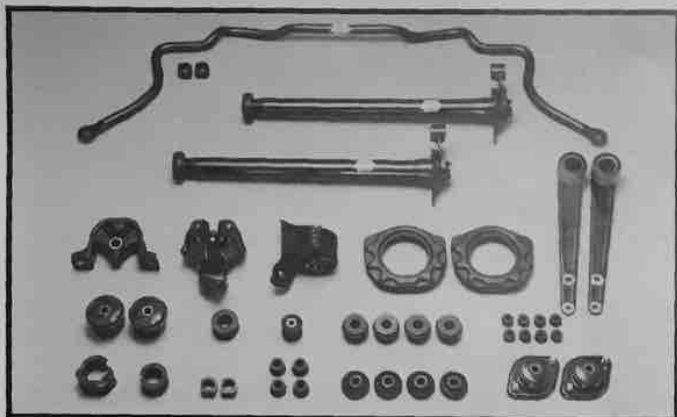

## MUGEN STABILIZER BARS

Mugen designs their stabilizer bars as factory replacements. By utilizing all the factory location points and hardware you will eliminate the breakage and noise commonly associated with after market stabilizer bars. Mugen stabilizer bars will noticeably increase the roll stiffness of your vehicle, providing much flatter cornering without a deterioration of ride.

### APPLICATION LIST - MUGEN STABILIZER BARS

CRX/Civic . . . 84-87	Integra . . . . . 86-89	CRX/Civic . . . 88-91
21 MM . . . . . Front	21 mm . . . . . Front	21 mm . . . . . Front
23 mm . . . . . Rear	23 mm . . . . . Rear	20 mm . . . . . Rear
		22 mm . . . . . Rear

## EIBACH SPORT SPRING KITS

Significant improvements in handling can be had with the inclusion of a Eibach Sport Spring Kit to your car. Immediately your car will react much quicker and more precisely to steering inputs. Transient and turn-in response will be noticeable improved, plus you will appreciate the lower stance and aggressive looks of your car. Eibach Sport Spring Kits use a truly progressive wound spring to maintain excellent ride quality. During compression the spring rate is increased, which results in greater resistance (the spring becomes stiffer) for excellent performance driving characteristics. All Eibach Sport Spring Kits use the highest quality, high-tensile Chrome Silicon Oil-Tempered spring steel available. The springs are then shotpeened for added durability and electrostatically powder coated for a superior high-quality finish. Because of these high standards, these Sport Spring Kits exceed the stringent requirements of the German TUV, a quasi-governmental authority which is fanatical about technical supervision and scrutiny. Average height reduction 1".

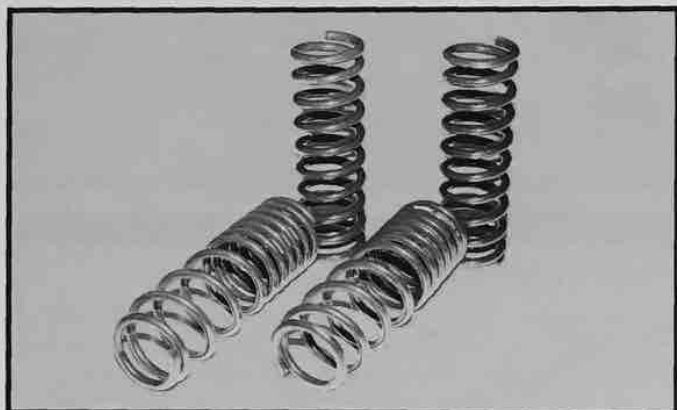

### APPLICATION LIST - SPORT SPRING KITS

Legend 4 dr . . . 86-89	Prelude . . . . . 88-91
Legend Cpe . . . 87-89	Accord . . . . . 86-89
Integra Rear . . . 86-89	Accord . . . . . 90-91
Integra . . . . . 90-91	CRX/Civic rear . . 84-87
Prelude . . . . . 83-87	CRX/Civic . . . . . 88-91

## MUGEN HARD BUSHING KIT

Performance driving, road racing or autocrossing can cause the stock rubber suspension bushings to deflect, causing a change in suspension geometry and loss of response. An example of this is the constant steering corrections required in a fast sweeping turn. Mugen designed these bushings with a very stiff, high durometer rated rubber to enhance response and lessen the chance of deflection. Because these bushings were made using O.E.M. molds, you can be assured of exact fit for each application.

(Application List page 4)

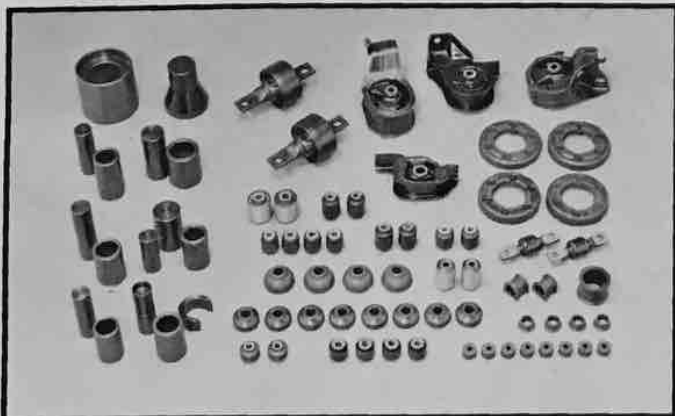

## APPLICATION LIST - MUGEN HARD RUBBER BUSHING KITS

### CRX/Civic 84-87 and Integra 86-89

Panhard Rod Bushing Set . . . . .	52360-XB2-SOR
Trailing Arm Bushing Set . . . . .	50209-XB2-SOR
Rear Spring Upper Seat Rubber . . . . .	52691-XB2-SOR
Front Stabilizer Bar Bushing Set . . . . .	51315-XB2-SOR
Front Stabilizer Rubber Set . . . . .	51312-XB2-SOR
Steering Box Cushion Set (CRX/Civic only) . . . . .	53434-XB2-SOR
Radius Arm Bushing Set . . . . .	51396-XB2-SOR
Rear Stabilizer Rubber Set . . . . .	52314-XB2-SOR
Mount Complete, Front Damper . . . . .	51920-XA1-083
Lower Front Arm Set . . . . .	51301-XB2-SOR

### CRX/Civic 88-91

Engine Mount Set . . . . .	50800-XE5-SONO
Front Upper Arm Set . . . . .	51455-XE5-SONO
Front Lower Arm Set . . . . .	51393-XE5-SONO
Front Radius Rod Set . . . . .	51395-XE5-SONO
Front Shock Absorber Fork Set . . . . .	51810-XE5-SONO
Front Stabilizer Set . . . . .	52316-XE5-SONO
Rear Stabilizer Link Set . . . . .	52314-XE5-SONO
Compensator Arm Set . . . . .	52343-XE5-SONO
Rear Lower Arm Set (88 only) . . . . .	52365-XE5-SONO
Rear Trailing Arm Set . . . . .	52385-XE5-SONO
Rear Upper Arm Inner Bushing Set . . . . .	52393-XE5-SONO
Rear Upper Arm Outer Bushing Set . . . . .	52395-XE5-SONO
Steering Box Cushion Set . . . . .	53434-XE5-SONO
Rear Shock Absorber Mount Set . . . . .	51631-XE5-SONO
Front Spring Mount Set . . . . .	51686-XE5-SONO
Rear Spring Mount Set . . . . .	52686-XE5-SONO
Front Stabilizer Set (18 mm) . . . . .	51316-XE5-SONO-B1

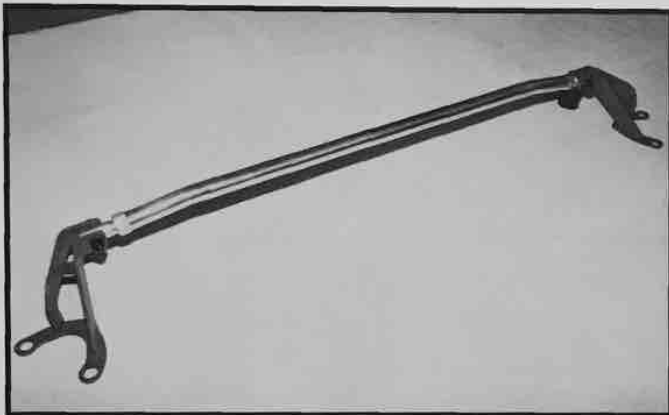

## KMS UPPER STRESS BAR

Stress bars help to eliminate chassis flex common with high performance Hondas. KMS stress bars are beautifully crafted for exact fit without any alterations. Side to side shock tower flex which can cause camber changes is minimized, creating a stiff, rigid chassis so necessary for performance driving. Installation time is less than 10 minutes.

### APPLICATION LIST - KMS STRESS BARS

CRX/Civic . . . . .	84-87
Integra . . . . .	86-89
CRX/Civic . . . . .	88-91

## MOTUL BRAKE FLUID

For the past three racing seasons, KMS used Motul brake fluid with great success. This DOT 3 synthetic brake fluid has an extremely high boiling point. We have also supplied this fluid to numerous endurance race teams, all having tremendous success. The brake fluid should be considered mandatory for any application involving continuous high temperature use.

## CARBON METALLIC BRAKE PADS

### Race

In many instances brakes are the deciding factor in winning, losing or the Tire Wall! KMS has proven again and again from our National Championship GT-3 CRX to our Escort World Challenge CRX team that these pads work. Carbon metallic race pads are furnished in three levels of hardness to suit the needs of car and driver. Please call us so we can tailor the compound to your needs.

### Performance Driving

A spin-off of our race program are these brake pads designed specifically for performance driving and autocrossing. Did you ever buy metallic brake pads that destroyed your brake rotors? We have, and this live-with-it trait is now a thing of the past. These pads are designed to build heat quickly and work well in continuous high heat applications, perfectly suited to the performance driver.

### APPLICATION LIST

#### Carbon Metallic Race Pads

CRX/Civic Front . . . . .	84-87
CRX/Civic Rear . . . . .	84-87
CRX/Civic Front . . . . .	88-91
CRX/Civic Rear . . . . .	88-91

#### Carbon Metallic Performance Pads

CRX/Civic Front . . . . .	84-87
CRX/Civic Rear . . . . .	84-87
CRX/Civic Front . . . . .	88-91
CRX/Civic Rear . . . . .	88-91

## STAINLESS STEEL BRAKE LINES

The next step in your braking system upgrade should be the inclusion of a KMS stainless steel brake line kit. The constant application and high heat encountered in performance driving can cause the stock rubber brake lines to contract and expand causing a mushy brake pedal. All KMS stainless steel brake line kits are furnished preassembled by our technicians and use all Aeroquip lines and fittings. A bit more expensive than the prepackaged kits available, but the care and quality that go into a KMS kit are well worth the investment.



### APPLICATION LIST – STAINLESS STEEL BRAKE LINE KITS

CRX/Civic . . . . . 84-87

CRX/Civic . . . . . 88-91

## MUGEN ROAD WHEELS

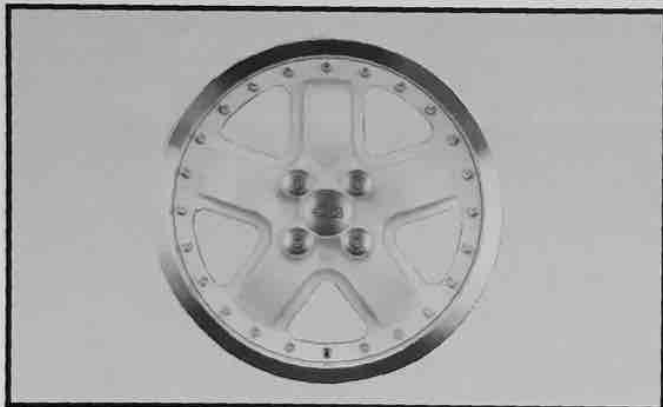

### Mugen MR-5 Wheels

Spectacular styling and uncompromising quality are the key phrases used in describing the new Mugen MR-5 Wheel. This 3-piece modular wheel combines low temperature, low pressure die cast aluminum rims with forged aluminum centers for an extremely strong, yet incredibly lightweight package. As with all Mugen wheels, the MR-5 wheel is hub-centric and has the correct offset for all Honda/Acura applications.

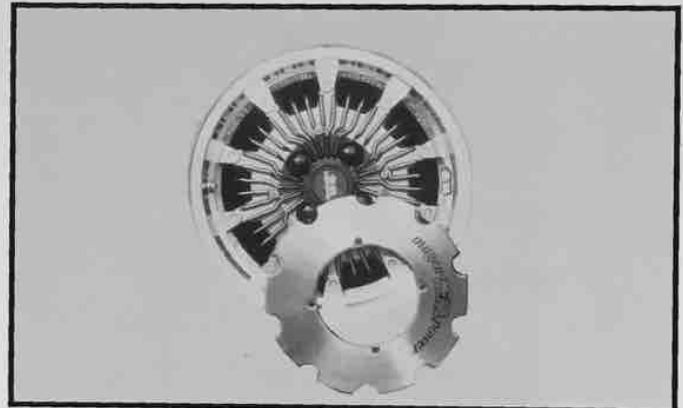

### Mugen CF-48 Wheels

Unique in style and design, Mugen's one piece cast aluminum wheels use a fan cowl design to help direct air where it's needed most—your brakes. If you prefer the looks without the cowl, simply remove four small bolts with the tool provided. All Mugen wheels are hub-centric and have the *correct* offset for optimum handling and reliable performance. Also, because of their unique design and construction, Mugen wheels are among the lightest and strongest wheels available.

### APPLICATION LIST – MUGEN CF48 AND MR-5 WHEELS

**CF 48** – All Honda/Acura with 4 x 100 mm bolt pattern

Sizes	Colors
13 x 5.5	Silver
14 x 6	Black
15 x 6	White, Gun Metal Grey

**MR-5** – All Honda/Acura with 4 x 100 mm bolt pattern

Sizes	Colors
14 x 6	Silver
15 x 6	Black
All sizes available in all colors.	

### ABOUT TIRE/WHEEL SIZES

What is the largest wheel and tire combination that will fit my Honda or Acura? This common question should be, "What is the *correct* wheel and tire combination for my car?" Large and wide wheels (16" x 6.5" or 7") with super low profile tires are definitely *not* the correct set-up. While this combination certainly looks great, having to deal with the downfall such as darting, poor tracking and straight line stability far outweigh good looks. Do yourself a favor and limit yourself to a plus-one set-up with a 6" wide wheel for best handling.

## ENGINE

Honda engines are marvelous powerplants. They are efficient, reliable, clean and powerful. They also respond very well to a little "tuning." The products listed in this section of the catalog are designed to enhance all the attributes of your engine without turning it into a "time bomb." For this reason you will not see turbo kits or nitrous oxide kits listed in our catalog. We believe in horsepower the old fashioned way, through the correct application of intake, camshaft, and exhaust technology.

## MUGEN EXHAUST SYSTEMS

The very first step to increased engine performance should be in your exhaust system. This change will produce the most horsepower per dollar and is the basis for all further engine development. Mugen feels it is impossible to produce a power change without a bolt-on tailpipe. Therefore Mugen carefully designs its exhaust system with increased tubing diameters, special silencers and rear silencers to produce more torque and horsepower than any after market system currently available. All Mugen exhaust systems are designed as direct O.E.M. replacements and use all existing mounting locations for easy installation. Each exhaust system is constructed with aluminized steel, coated with a tough baked-on heat resistant paint to protect against corrosion. Sound quality is enhanced with a deep throaty tone that does not detract from overall interior sound levels. All necessary O.E.M. mounting hardware is included along with comprehensive assembly instructions.

### APPLICATION LIST - MUGEN EXHAUST SYSTEM

CRX 1500 . . . . .	84-87	Civic 1500 . . . . .	85-87	CRX . . . . .	88-91
CRX SI . . . . .	85-87	Civic SI . . . . .	86-87	Civic . . . . .	88-91

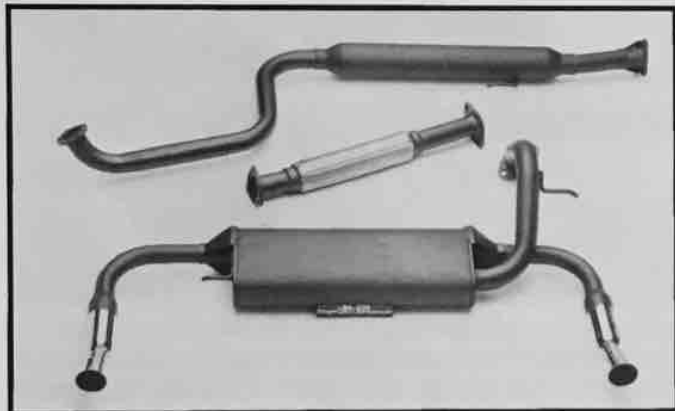

1984-1987 CRX/Civic

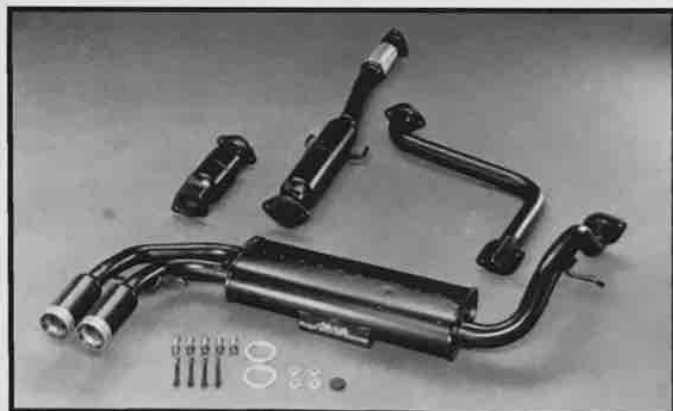

1988-1991 CRX/Civic

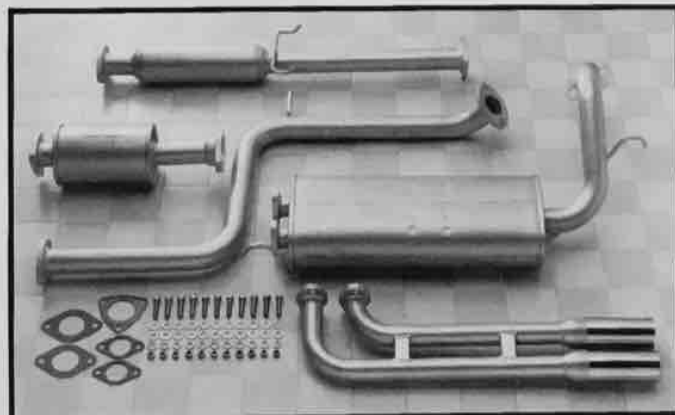

## HKS SPORT EXHAUST

For applications that Mugen does not make an exhaust system, KMS recommends and uses HKS Sport Exhaust Systems. HKS Sport Exhaust Systems are not to be confused with common "bolt-on" mufflers which do little but add noise. The HKS System is a complete tuned exhaust that is a direct bolt-on replacement, eliminating cutting, welding, or fabricating of any kind. Each system is constructed from high quality aluminized steel to insure long exhaust life. The HKS Sport Exhaust has an exceptionally quiet exhaust note, deep and throaty, but not objectionable.



## APPLICATION LIST - HKS SPORT EXHAUST SYSTEMS

Integra . . . . .	86-87	CRX SI . . . . .	86-87
Integra . . . . .	88-89	Civic SI . . . . .	85-87
Integra . . . . .	90-91	CRX SI . . . . .	88-91
Prelude SI . . . . .	85-87	Civic SI . . . . .	88-91

## MUGEN EXHAUST MANIFOLD

After you have changed your stock exhaust system, the next step towards increased engine performance is the addition of a Mugen exhaust manifold. Mugen has chosen a Tri-Y design for their exhaust manifold after considerable development and dyno time. Although it is true a 4 into 1 design will produce more ultimate horsepower, this only happens at very high RPM and is suitable for racing purposes only. A Tri-Y design will consistently produce more power throughout a *broader* RPM band than any 4 into 1 design. The reason that most manufacturers use the 4 into 1 design is because they are very inexpensive to produce. All Mugen exhaust manifolds use TIG/Gas welds which are superior in strength and finish to other products on the market. Also, instead of a cold bending process which produces a tubing size reduction, Mugen uses a costly sand bending method for absolutely uniform tube dimensions. All Mugen exhaust manifolds come complete with O.E.M. gaskets and mounting hardware for long lasting trouble-free performance.

### TOP RIGHT:

*A Mugen technician demonstrates the sand bending technique used on all Mugen exhaust manifolds.*

### RIGHT:

*An example of a sharp-angle without any tubing size reduction.*

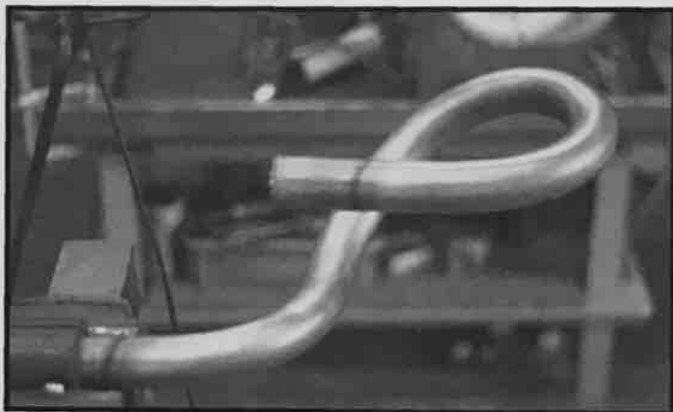

## APPLICATION LIST

### MUGEN EXHAUST MANIFOLD

CRX/Civic 1500 . . . . .	84-87
CRX/Civic SI . . . . .	85-87
CRX/Civic . . . . .	88-91
Integra . . . . .	90-91

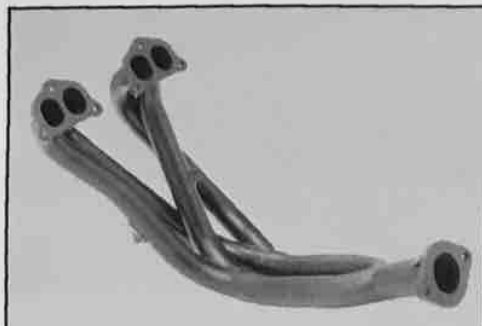

84-87 CRX/CIVIC

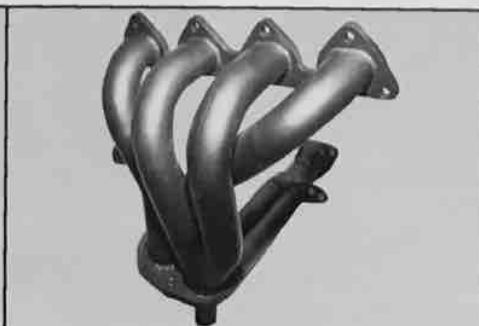

88-91 CRX/CIVIC

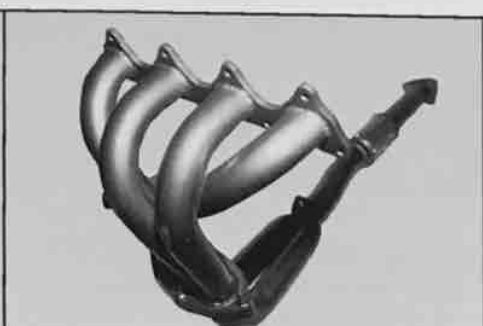

90-91 INTEGRA

## MIKUNI TWIN SIDEDRAFT KIT

From a performance standpoint, the standard carburation on the 1.5 litre CRX/Civic is very hard to work with. When modifying your car for autocross or performance driving, it becomes necessary to change induction. The Mikuni Twin Sidedraft Carb Kit will satisfy the need for power but will also be tame enough for everyday driving. This kit will produce a very flat power band that starts at 2000 RPM and pulls to 8000 RPM. To take full advantage of the power capabilities of this kit, KMS recommends the use of a Mugen Exhaust manifold and silencer with a Mugen XA-1 camshaft. This kit comes pre-assembled, complete with comprehensive instructions and *all* hardware.



## 34/34 WEBER CONVERSION

After you've added a Mugen header and exhaust system to your 84-87 CRX/Civic, the next logical progression in performance is the induction system. Common 32/36 Weber conversion kits have proven to be inadequate for the 84-87 CRX/Civic. First and most important is the 32/36 Weber was designed for a longitudinal engine. When used on a transverse engine, the float bowl will starve in any cornering situation. The 34/34 Weber incorporates a central float bowl to eliminate fuel starvation. This conversion also has the correct venturi size to eliminate the flat spots common to the 32/36 Weber. Linkage problems are eliminated since this setup utilizes the stock cable. Each kit comes complete with adapter plates, gaskets, properly jetted carbs, and special air cleaner to bolt on to the stock manifold. SCCA IT Racing Legal.

## MUGEN INTAKE MANIFOLDS

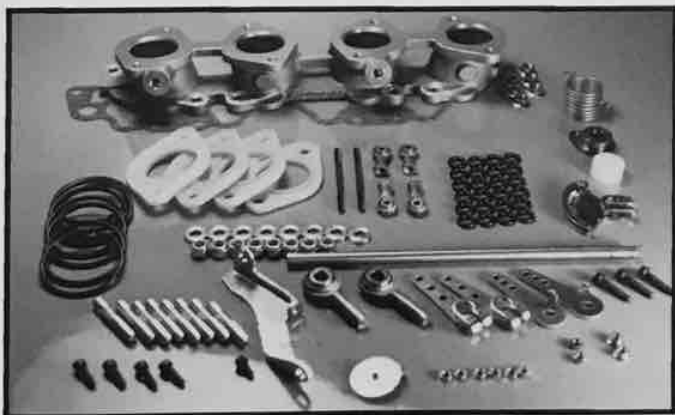

88-91 CRX/Civic

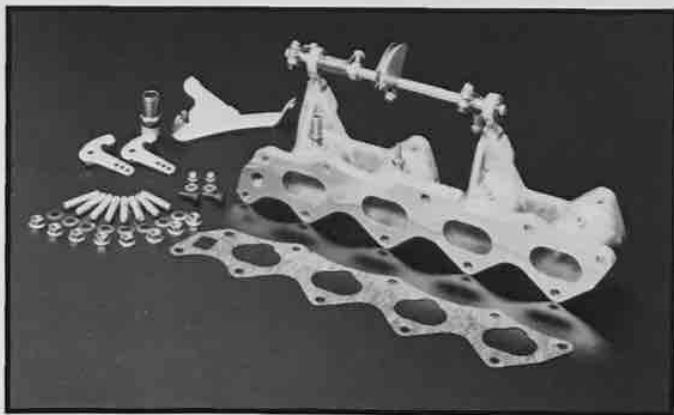

86-89 Integra

King Motorsports offers several intake systems for your Honda or Acura. All of these systems offer ease of installation along with superior performance and quality. Each system is tailored to the exact application and comes complete with correct linkage, air cleaners and gaskets necessary for installation.

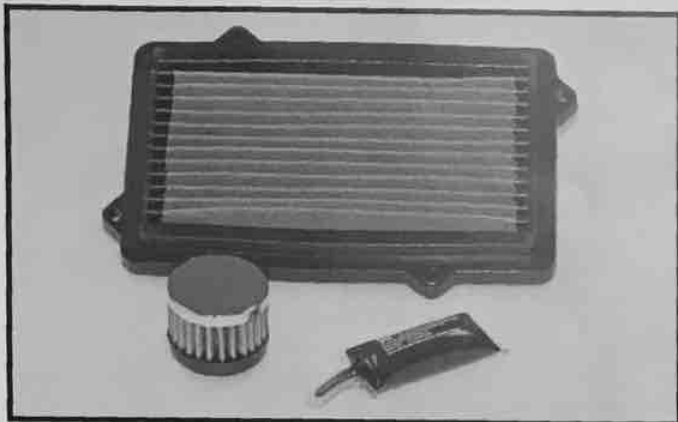

## K&N AIR FILTERS

While there may be no such thing as "free" horsepower, the K&N Air Filter comes very close. Ordinary paper air cleaners do an admirable job of filtering air, but clog easily, reducing air flow (CFM). A K&N Air Filter used for 40,000 miles will actually out flow a new foam or paper filter. When new, A K&N Air Filter flows double the amount of a foam or paper filter. K&N uses a washable cotton gauze element which is designed for the life of your engine, and will need to be cleaned every 50,000 miles. K&N engineers their filters to fit each application. K&N is so confident of their filter's performance and durability, they offer a free million mile warranty with each air filter.

### APPLICATION LIST - K&N AIR FILTERS

CRX/Civic 1500 . . . . .	84-87	Integra . . . . .	86-89	Integra . . . . .	90-91
CRX/Civic SI . . . . .	85-87	CRX/Civic . . . . .	88-91	Cleaning Kit	

## POWER-FLOW AIR FILTERS

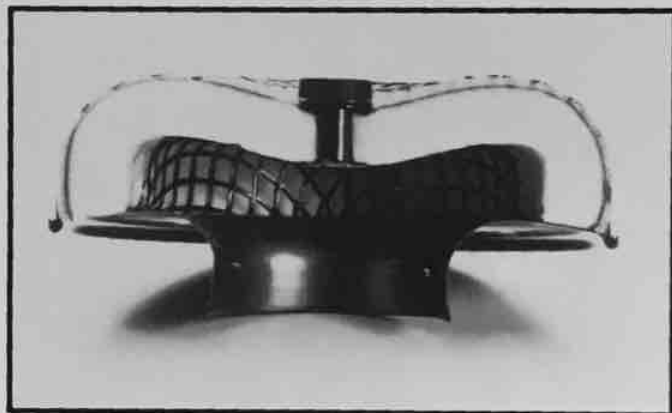

The Power-Flow air filter system is designed to further reduce air flow restriction caused by the stock air box. The design of the Power-Flow is like a large velocity stack which eliminates air turbulence before it reaches the throttle plate. The air filter element is a reusable foam for long life. Dyno testing this unit on a 91 CRX has shown a 5 horsepower gain. This unit is very easy to install and you will notice an immediate gain in throttle response.

### APPLICATION LIST - POWER-FLOW

Integra . . . . .	86-87	CRX/Civic SI . . . . .	84-87
Integra . . . . .	88-89	CRX/Civic . . . . .	88-91
Integra . . . . .	90-91		

### TECHNICAL INFORMATION ABOUT CAMS/COMPUTER "CHIPS"

At this time there are no performance "chips" available for the standard Honda ECU box. Because the stock fuel injection system is so refined there is nowhere to gain any extra horsepower. Remember, if your engine is fuel efficient and pollution-clean you also have the correct ingredients to make horsepower too. Beware of variable resistors disguised as adjustable "black boxes." They will essentially trick your engine into a cold start, full rich loop, which is not correct and potentially harmful to your engine.

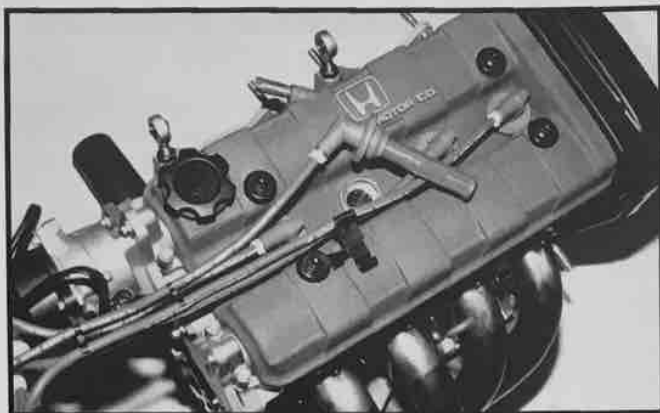

## ULTRA IGNITION WIRE SET

The weakest link in the typical Honda ignition system is neither the distributor nor coil, but the ignition wires. Maintaining a strong spark is essential for any performance application. The Ultra Ignition Wire Set is without a doubt the finest ignition wire set produced. Have you ever had an after-market set of ignition wires come apart in your hands when changing plugs? That common problem is eliminated with a special insulated boot and terminal end. These 8mm ignition wire sets are tailored to each application. Since they are shielded, there will not be any static picked up on stereos and tape players. Minimum loss of voltage through these wires means extra horsepower for you!

### APPLICATION LIST - ULTRA IGNITION WIRES

CRX/Civic 1500	84-87	Integra	86-87	Integra	90-91
CRX/Civic SI	85-87	Integra	88-89	Prelude	88-91
CRX/Civic	88-91				

## KING MOTORSPORTS AT THE RACES

Sometimes it's necessary to blow your own horn, so when it comes to racing, we are very proud of our achievements. Since 1981 KMS has won, or run in the top three in all racing series we have competed in, including winning two National Championships. Alone, that is quite an accomplishment... but add to that all cars were designed and constructed by KMS and all engines were developed and built by KMS, now that is something to blow your horn about. The point we are making is that we are not just a decal decorating someone's fender, along for the ride. We are an active motorsports company. When you call KMS you talk to people with hands-on experience. You will get candid answers to all questions from people who spend their days and nights in the pursuit of finishing first.

## KING MOTORSPORTS DEVELOPMENT AND FABRICATION

One of the most exciting divisions of KMS is our chassis development and fabrication department. Our research and development in this area has produced superior products, an example being our SCCA GT-3 National Championship winning CRX. KMS can help you in your pursuit of victory by offering that same technology and quality. From turn key cars in any class to component manufacture and race preparation, our trained staff is eager to help you!

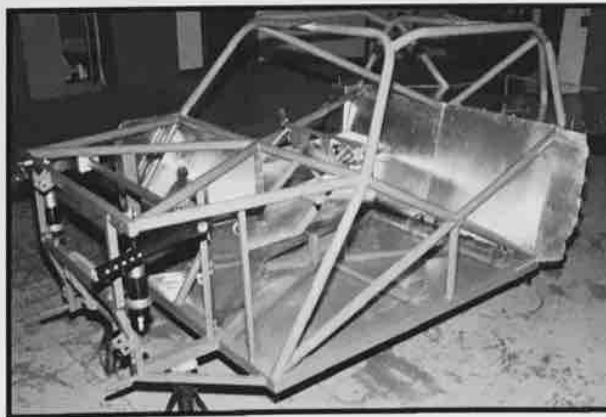

*KMS tube-frame GT-3 CRX under construction.*



*1989 SCCA GT-3 National Champion*

# WHAT IS MUGEN?



## F-3000

MUGEN is the manufacturer of the champion engine and supplying the engines to major F3000 teams in Europe and Japan.  
'89 Champion Engine in All Japan Series. '89 Champion Engine in FIA International Series.



## F-3

MUGEN has developed the title-winning engine and been supplying the engines to major F-3 teams in Europe and Japan.  
'88 & '89 Champion Engines in Japan. Seven victories in '89 British Series.



## Gr-A

MUGEN has been developing Gr-A Civic and campaigning in All Japan Turing Car Championship Series.  
Defending Manufacturer Champion from '87 to '89.

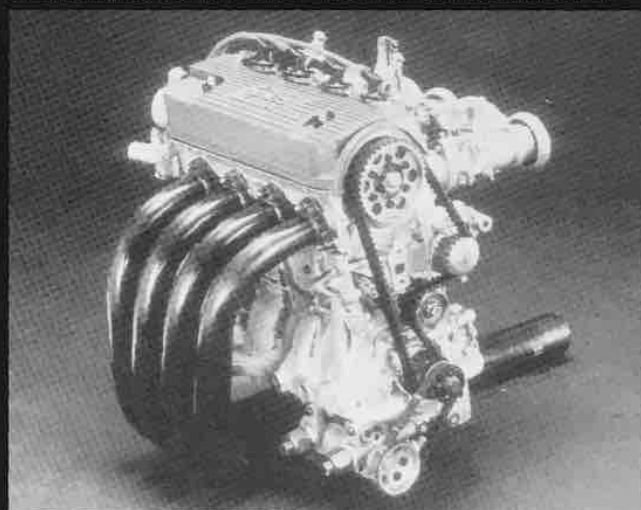

## SCCA GT-3

MUGEN has developed the champion engine for GT-3 CR-X and been supplying the engines to US users.  
'89 SCCA GT-3 Class Champion Engine.

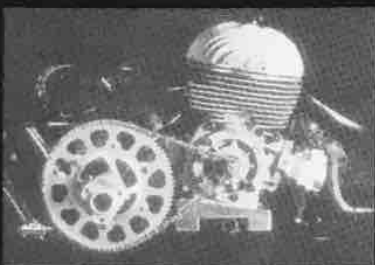

## KART

MUGEN has been producing and supplying kart engines for top karters.  
'88 Hong Kong Gp A-II Class Winning Engine.

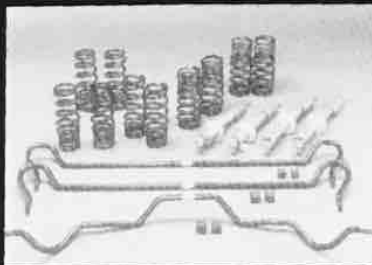

**COMPETITION PARTS** for Honda Racers  
MUGEN has been developing and supplying highly competitive parts for Honda cars and motorcycles.



**CUSTOMIZED PARTS** for Honda Enthusiasts  
MUGEN has been producing original styling and performance parts for Honda cars and motorcycles.

MUGEN **無限** POWER

# 無限 MUGEN

After many years of racing Honda Products exclusively, it is my desire to offer you the same championship winning parts that have helped me win races. Our company is dedicated to producing and marketing only the very finest products which have been proven under the most grueling conditions. We are very proud to be designated an "Authorized U.S. Distributor" for Mugen Co., Ltd. You can expect only the highest quality products from Mugen. We work very closely with Mugen and in the upcoming months you will see some very exciting new product releases. It is my personal committment to you that King Motorsports will strive to provide you with the best products for winning results.



Jim Denacci, President



PHONE 414-593-2800  
FAX 414-593-2627

**KING**  
Motorsports

## ENGINE DEVELOPMENT SERVICES

While it is relatively "easy" to make horsepower with your Honda or Acura, making it live and be reliable is the real "trick." For this reason KMS offers its engine development services for all IMSA and SCCA racing classes plus engines for high performance driving. At KMS all critical machining is done in-house. This assures us of the absolute in accuracy, precision and quality for each engine. All engines are assembled using only Honda OEM gaskets, seals and filters... no cheap substitutes. KMS has over ten years of experience in developing and winning with Honda and Acura engines. Because each engine is tailor-made, please call for more information.

## DYNO SERVICES

The most valuable tool necessary for comprehensive engine development is an engine dyno. Without the use of an engine dyno maximum horsepower and reliability cannot be achieved. The elimination of guesswork is the difference between an average engine and a truly fine tuned powerful engine. For this reason KMS offers customer dyno services using our computer-equipped Stuska Dyno. KMS offers this service for all Honda and Acura engines. Please call for more information.

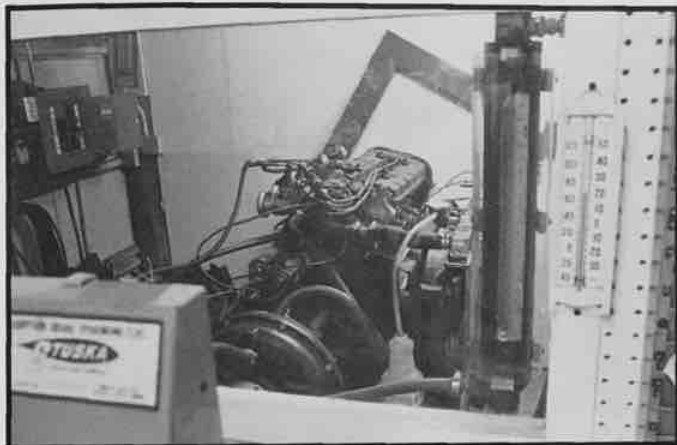

A King Motorsports/Mugen Power Engine on the dyno at King Motorsports engine-building facility.



Mugen GT-3 1.6 SOHC CRX engine 215 H.P.

## ADJUSTABLE CAM GEAR

When deck heights of blocks or heads are milled to achieve higher compression, cam timing is effectively retarded. The KMS Adjustable Cam Gear will enable you to bring your cam timing into spec. Due to our unique design, these gears have proven to be totally reliable in racing use.

### APPLICATION LIST ADJUSTABLE CAM GEAR

Civic	1200
CRX/Civic	84-87
Integra	86-89

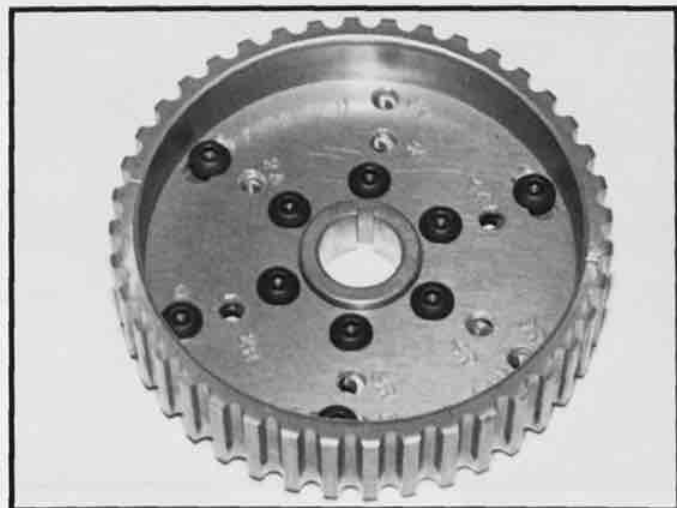

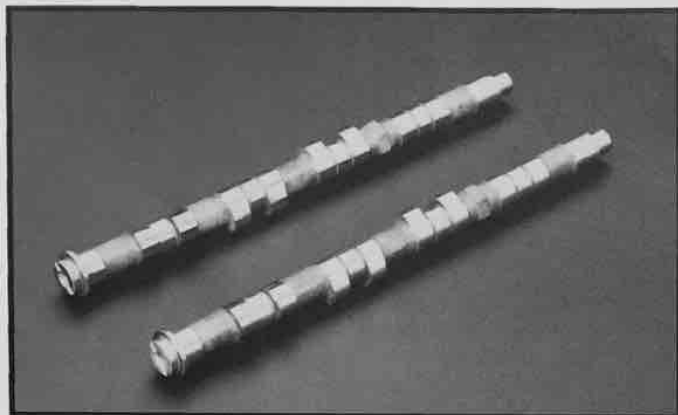

## MUGEN CAMSHAFTS

Mugen camshafts are the very finest camshafts available for your Honda or Acura. All Mugen camshafts are produced using new billets and are correctly heat treated for O.E.M. longevity. Because Mugen is able to use new billets, they have no limitation in designing a cam that produces more power and a broader power-band than any re-ground camshaft available. These cams are not designed for stock fuel injection.

### APPLICATION LIST - MUGEN CAMSHAFTS

CRX/Civic . . . . .	84-87	10/40 Performance
CRX/Civic . . . . .	84-87	25/55 Race
Integra . . . . .	86-89	10/40 Performance
Integra . . . . .	86-89	25/55 Race
CRX-Civic . . . . .	88-91	10/40 Performance

## KMS FI CAMSHAFTS

Finally, after much research, dyno work, and road testing, KMS has developed a cam shaft for the FI that really works. Previously, FI camshafts on the market basically changed your powerband, some have all high RPM with very bad low-end torque. Other FI camshafts get good low-end RPM by sacrificing high-end punch, and the worst did nothing at all! But the most aggravating sacrifice has been poor idle quality. With a KMS FI camshaft you can expect a nice smooth idle with good off-idle response and a powerband starting at 2000 RPM continuing on to 6500 RPM. Proper heat-treating ensures long camshaft life, and a proper base circle gives you a quiet running camshaft.



### KMS FI CAMSHAFT SPECIFICATIONS

CRX/Civic SI	85-87	Intake/exhaust	Integra	86-87	Intake/exhaust
Lift	.386	Intake	Lift	.430	Intake/exhaust
Duration	260 degree	Exhaust	Duration	258 degree	Intake/exhaust
	280 degree				

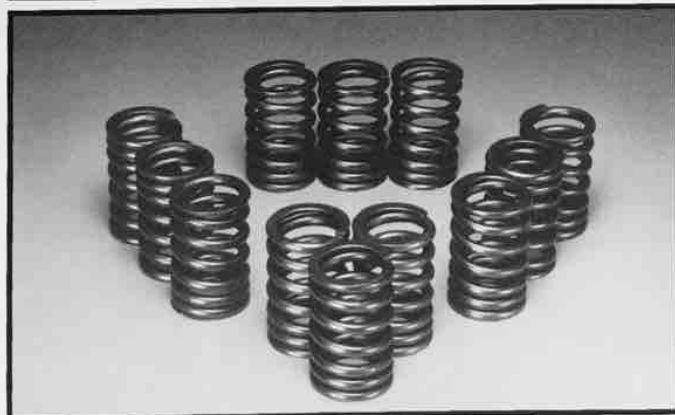

## MUGEN VALVE SPRINGS

The use of a high-lift camshaft such as the Mugen XA-1 dictates the use of a Mugen Valve Spring Kit. The combination of a high-lift cam and high RPM can cause the stock springs to float or oscillate resulting in loss of horsepower and potential damage to the valve train. The Mugen Valve Spring Kit will eliminate these potential problems, giving you a trouble-free, reliable valve train.

### APPLICATION LIST - MUGEN VALVE SPRINGS

CRX/Civic . 84-87	Integra . . 86-89	CRX/Civic . 88-91
-------------------	-------------------	-------------------



## MUGEN POLISHED VALVES

Mugen uses stock O.E.M. valves with great confidence in their own race engines. These valves, though, have received the "Mugen Touch." Each valve is lightened and highly polished to increase intake and exhaust flow, while maintaining the longevity and reliability of the standard steel valves.

### APPLICATION LIST - MUGEN POLISHED VALVE SET

CRX/Civic 1500 . . . . .	84-87
Integra . . . . .	86-89

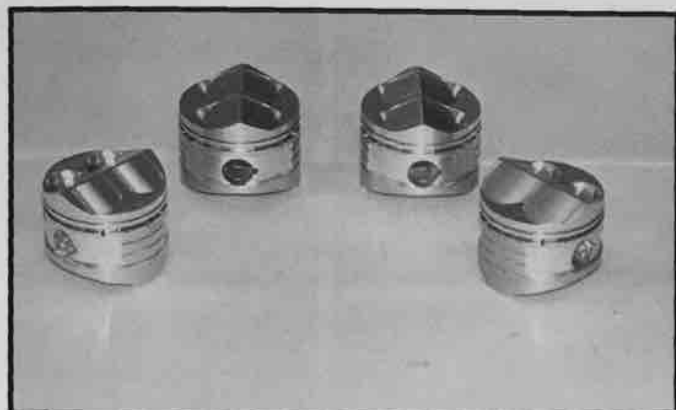

## KMS FORGED PISTONS

The design of a racing piston is one of the most complex aspects of a racing engine. KMS has spent literally hundreds of hours on the design of our forged pistons. Many dome-shaped configurations have been tested in order to get the ultimate flame travel. The result of all this work are pistons that produce the most horsepower on our dyno and have proven durable in our race cars. All pistons are full floating and come complete with rings and wrist pin clips.

### APPLICATION LIST - KMS FORGED PISTONS

Available for: Civic 1200 EB1, EB2, EB3; CRX 1.5 litre, Integra, Prelude, 88-91 CRX/Civic.

## MUGEN BIG-BORE PISTON KITS

There's no substitute for cubic inches, or so it is said. Mugen over-bore piston kits increase the piston bore diameter with a special cast hi-compression piston. While this increases horsepower, it also noticeably increases torque at a lower RPM creating a very gutsy powerband. For use with the stock cam and injection or Mugen sport cams and dual Mikuni induction, the Mugen over-bore piston kit will solve your small displacement blues.

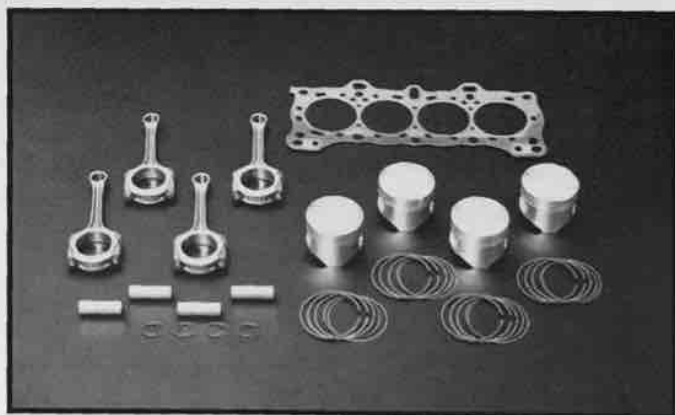

### APPLICATION LIST - MUGEN BIG-BORE PISTON KIT

Integra . . . . .	86-89
CRX . . . . .	88-91

## CRX HIGH COMPRESSION PISTONS (1.5 litre)

By raising the compression of the 1.5 litre engine you will noticeably improve horsepower throughout the entire RPM range. These cast pistons use only one compression ring to lessen piston drag. These pistons are suitable for all performance work and are extremely reliable. With a standard CVCC cylinder head, the compression ratio is 10.2 to 1 and Si heads will have 10.0 to 1 compression.

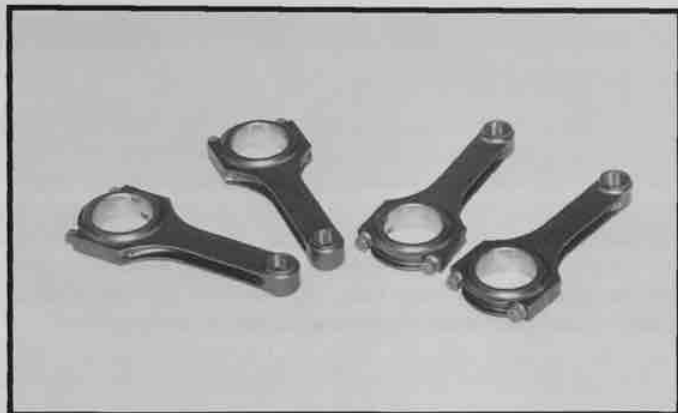
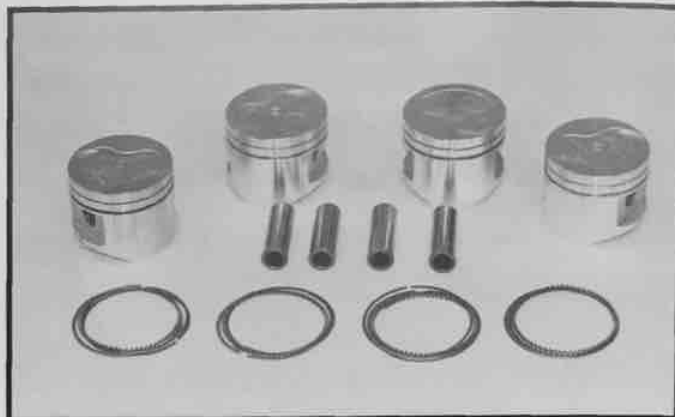

## FORGED STEEL RODS

Typically the weakest internal engine component in a Honda are the connecting rods. Any continuous use over 8000 RPM will usually result in rod failure. For this reason all KMS performance engines use forged steel rods and we highly recommend their use. Over a 7-year period we have not seen any connecting rod failure, a strong tribute to their quality. All forged steel connecting rods come in a matched set.

### APPLICATION LIST - FORGED STEEL RODS

Civic 1200		Integra . . . . .	86-89
Prelude . . . . .	83-87	CRX/Civic . . . . .	88-91
CRX/Civic . . . . .	84-87		

## MUGEN HEAD GASKETS

Mugen supplies special head gaskets for performance use. Mugen head gaskets are designed for the abuse hi-compression and high stress can place on a head gasket, eliminating any sealing problems.

### APPLICATION LIST - MUGEN HEAD GASKETS

CRX/Civic . . . . .	84-87	
Integra . . . . .	86-89	75 mm
		76 mm
CRX/Civic . . . . .	88-91	76 mm

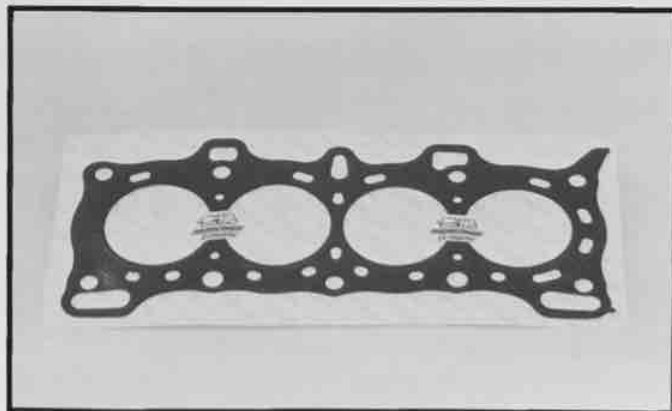

## MUGEN BEARINGS

When used for racing and/or under high stress, the standard Honda bearings have proven to be inadequate. Mugen uses Clevite F-77 material for its bearing construction, which is a racing industry standard. These bearings are extremely durable and will not scuff or flake like the standard bearings can. These bearings are a must for all racing applications. Available for 86-89 Integra, 88-91 CRX/Civic.

## APPLICATION LIST - MUGEN BEARINGS

### Connecting Rod Bearing Sets - 8 Pieces

13211-XB2-SORA "A" Blue T=1.5	(+0.013)(-0.010)
13212-XB2-SORA "B" Black	(+0.010)(+0.007)
13213-XB2-SORA "C" Brown	(+0.007)(+0.004)
13214-XB2-SORA "D" Green	(+0.004)(+0.001)
13215-XB2-SORA "E" Yellow	(+0.001)(-0.002)
13216-XB2-SORA "F" Pink	(-0.002)(-0.005)
13217-XB2-SORA "E" Red	(-0.005)(-0.008)

### Main Bearing Sets - 10 Pieces

13321-XB2-SORA "A" Blue T=2.0	(+0.016)(+0.013)
13322-XB2-SORA "B" Black	(+0.013)(+0.010)
13323-XB2-SORA "C" Brown	(+0.010)(+0.007)
13324-XB2-SORA "D" Green	(+0.007)(+0.004)
13325-XB2-SORA "E" Yellow	(+0.004)(+0.001)
13326-XB2-SORA "F" Pink	(+0.001)(-0.002)
13327-XB2-SORA "E" Red	(-0.002)(-0.005)

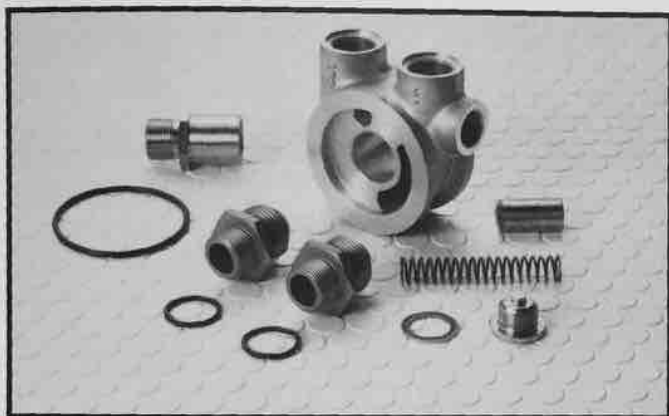

## MUGEN OIL COOLER ADAPTER

This kit is required when using an external oil cooler (highly recommended for racing). It is equipped with an internal pressure relief valve and is designed to use the stock oil filter. This kit uses Aeroquip-12 fittings.

### APPLICATION LIST MUGEN OIL COOLER ADAPTER

CRX/Civic . . . . .	84-87
Integra . . . . .	86-89
CRX/Civic . . . . .	88-91

## TRANSAXLE

Honda has, without a doubt, the most precise, smoothest shifting gearbox of all front wheel drive cars. But, as always a little "help" in this area goes a long way. Usually the stock clutch components are the weak links, although the 1990-91 CRX/Civic clutch has held up remarkable well in racing conditions. Lightened flywheels add great response to your engine's powerband. Any serious racer will consider the Mugen Limited Slip and Close-ratio Gears mandatory.

## MUGEN CLUTCH

When your Honda or Acura starts to generate the horsepower level it is capable of, the weak link becomes the stock clutch. Mugen perfected this clutch in the N-1 race series in Japan. These grueling entry-level races are a torture test for a clutch, and the Mugen clutch has proven to be completely trouble-free. This clutch is entirely streetable and does not increase pedal pressure. This clutch should be considered mandatory for any performance application or as a stock replacement.

### APPLICATION LIST - MUGEN PERFORMANCE CLUTCH

Integra . . . . .	86-89	CRX/Civic . . . . .	88-89
-------------------	-------	---------------------	-------

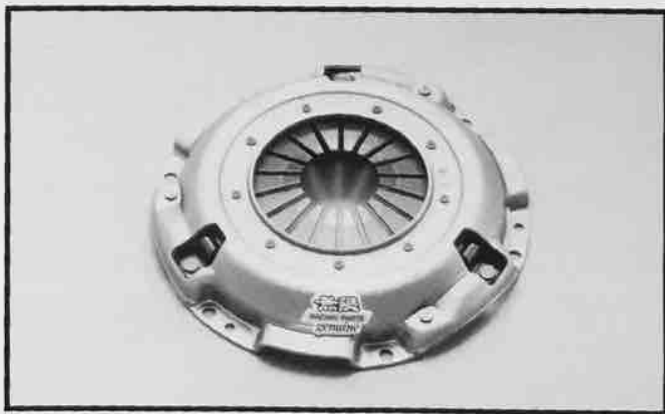

## LITE FLYWHEELS

A lite flywheel will increase engine response allowing your engine to rev much quicker. This is very useful for performance driving and autocrossing, which places a premium on engine flexibility. KMS uses only new flywheel cores which are machined to the desired weight and balanced for vibration-free performance. All Honda/Acura applications.

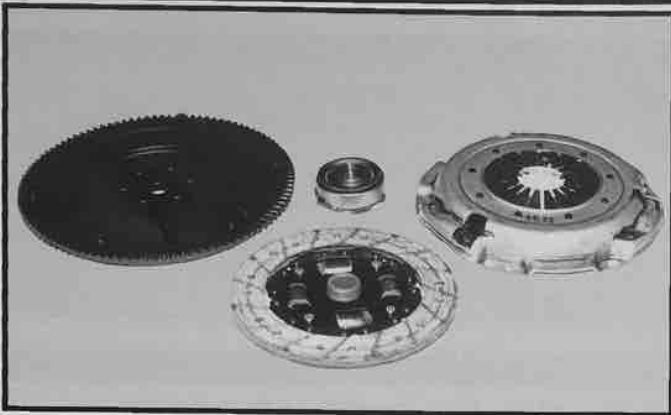

## CRX/CIVIC HIGH PERFORMANCE CLUTCH/FLYWHEEL

Once this engine is producing to its potential, **NO** bolt-on aftermarket clutch will withstand the punishment. For this reason King Motorsports designed a flywheel to incorporate our Mugen Integra Clutch. This 10 lb. ductile iron flywheel was made specifically for this application. This is not a reworked or lightened stock flywheel, but a purpose-built flywheel. The Mugen Integra Clutch offers three times the clamping force of a stock clutch at ALL RPMs, not just at extremely high RPMs like a Centerforce unit. It is perfect for high torque applications such as turbo or nitrous systems which cause every other clutch to slip. Complete bolt-on package with all pieces included: flywheel, disc, pressure plate, and modified throw-out bearing.

## MUGEN LIMITED SLIP DIFFERENTIAL

The Mugen Limited Slip Differential will eliminate traction loss through wheelspin in a high performance Honda or Acura by using a multiple disc system which is torque sensitive. The more power that is applied, the tighter it engages. Power can be applied sooner and more effectively through a corner resulting in quicker lap times.

### APPLICATION LIST — MUGEN LIMITED SLIP DIFFERENTIAL

CRX/Civic . . . . .	84-87
Integra . . . . .	86-89
CRX/Civic . . . . .	88-91



## MUGEN CLOSE-RATIO GEARS

Racing engines with narrow power bands require the use of close-ratio gear sets to ensure the engine will always be in its powerband. Mugen designed these gear sets for the 86-89 Integra transmission. Their worth has been competition proven with many IMSA and SCCA championships. Mugen used special helical cut gears to reduce drive line shock. They also incorporate a heavy duty synchro design for smooth shifts.

### APPLICATION LIST — MUGEN GEARS

MAIN SHAFT SET A (2.250/1.650):	23210-XB3-SORS-A	GEAR SET 4TH D (1.208):	23450-XB3-SORA-C	GEAR SET FINAL B (4.266):	41200-XB2-SORA-B
MAIN SHAFT SET B (2.053/1.590):	23210-XB3-SORS-B	GEAR SET 5TH E (1.103):	23460-XB3-SORS-E	GEAR SET FINAL C (4.461):	41200-XB2-SORA-C
MAIN SHAFT SET C (1.900/1.590):	23210-XB3-SORS-C	GEAR SET 5TH A (0.967):	23460-XB3-SORS-A	GEAR SET FINAL D (4.651):	41200XB2-SORA-D
MAIN SHAFT SET D (2.053/1.789):	23210-XB3-SORS-D	GEAR SET 5TH B (1.031):	23460XB3-SORS-B	GEAR SET FINAL E (3.800):	41200-XB3-SORS-E
GEAR SET 3RD A (1.347):	23440-XB3-SORS-A	GEAR SET 5TH C (1.042):	23460-XB3-SORS-C	GEAR SET FINAL F (3.933):	41200-XB3-SORS-F
GEAR SET 3RD B (1.304):	23440-XB3-SORS-B	GEAR SET 5TH D (1.083):	23460-XB3-SORS-D	GEAR SET FINAL G (4.000):	41200-XB-SORS-G
GEAR SET 3RD C (1.410):	23440-XB3-SORS-C	GEAR SET 5TH E (1.103):	23460-XB3-SORS-E	GEAR SET FINAL H (4.142):	41200-XB3-SORS-H
GEAR SET 4TH A (1.103):	23450-XB3-SORA-A	GEAR SET 5TH F (1.160):	23460-XB3-SORS-F	GEAR SET FINAL I (4.384):	41200-XB3-SORS-I
GEAR SET 4TH B (1.160):	23450-XB3-SORA-B	GEAR SET FINAL A (4.071):	41200-XB2-SORA-A	GEAR SET FINAL J (4.538):	41200-XB3-SORS-J

## 4.93 FINAL DRIVE CRX-CIVIC

For SCCA IT racing a 4.93 Final Drive will make the stock 84-7 CRX/Civic much more useful. Instead of just using 3rd or 4th gear you will be able to use 2nd through 5th effectively. Exit speed out of corners will be greatly increased as well as acceleration through the gears. CRX-Civic 84-87.

## MUGEN SPORT STEERING WHEEL

If the most direct link between a driver and his/her car is the steering wheel, a Mugen Steering Wheel can change your whole driving experience. This handsome 13.5" steering wheel looks as great as it feels! Constructed from black anodized aluminum and bound in rich black leather for a sure and comfortable grip, the Mugen Steering Wheel should be mandatory for any serious Honda/Acura aficionado. Included in each kit is the "Mugen Power" horn button. Also available is a matching leather-bound horn pad cover embossed with the "Mugen Power" logo.



## MUGEN EVOLUTION II STEERING WHEELS



The Evolution II Mugen Steering Wheel was designed by Mugen and constructed in Italy by Momo. It is a beautiful handcrafted leather wheel that is anatomically correct for fatigue-free driving. Available in standard form or specially prepared for cars with cruise control, the Evolution II Mugen Steering Wheel is a most unique addition to any Honda or Acura automobile.

### APPLICATION LIST

- Mugen Sport Steering Wheel**  
All Honda/Acura except Cruise Control
- Mugen Evolution II Steering Wheel**  
All Honda/Acura including Cruise Control

## MUGEN REAR SPOILERS

Not only does the addition of a Mugen Rear Spoiler enhance the appearance of your car, but they are functional as well. Wind tunnel designing creates down-force to help keep the rear of your car behind you! All Mugen Rear Spoilers are easy to install without holes to drill. Your Honda or Acura will stand out among the crowd with the addition of a Mugen Rear Spoiler.



88-91 CRX



84-87 CRX



84-87 Civic



86-89 Integra



90-91 Integra

### APPLICATION LIST - MUGEN REAR SPOILERS

CRX	84-87	White
Civic	84-87	Black
Prelude	83-87	Black
Integra	86-89	Red, White, Black
CRX	88-91	Black, Yellow, Red, White
Integra	90-91	Unpainted

## MUGEN BODY KITS

Mugen has spent considerable time and effort to produce what we feel is the finest body kit on the market. Mugen's fiberglass fit and finish is unparalleled in the industry. What this means to you is a kit that fits right the *first* time without the usual problems associated with body kits in general. Included with each kit are extensive assembly instructions, and all O.E.M. mounting hardware.



90-91 Integra



84-87 CRX



88-91 CRX



88-91 Civic



86-87 Integra

## APPAREL/DRIVER ACCESSORIES



### Mugen Poloshirts / Jackets

Attractive with contemporary styling is how one would best describe "Mugen Power" sportswear. The Lightweight Racing Jackets feature a light poly fill to keep out the morning chill, yet are comfortable enough for all day use. The Interlock Shirts are made from 50/50 poly-cotton blend and will look great at the track or at other leisure time activities. Best of all both come embroidered with the "Mugen Power" emblem so everyone knows you are a formidable competitor.



### KMS T-Shirts / Sweatshirts

Show 'em how you got to be so fast with our colorful KMS T-shirts and sweatshirts. These 100% cotton 3-color T-shirts and sweatshirts depict the GT-3 National Championship King Motorsports CRX on the back and have the KMS logo on the front.

Specify size on order sheet.

## MUGEN KEYCHAINS, STICKERS, DECALS, EMBLEMS & PATCHES

*Who is the fastest?*

*You are, with Mugen Power!*

Proudly display how you got so fast with these distinctive and attractive Keychains, Decals, Emblems and Patches.



### MUGEN NEW EMBLEM SILVER

90000-YZ8-0002-S  
90000-YZ8-0002-L

13- (S) W110mm x H13mm  
18- (L) W150mm x H16mm



### MUGEN EMBLEM SILVER

90000-YZ8-S001-S  
90000-YZ8-L001-S

13- (S) W120mm x H22mm  
18- (L) W161mm x H30mm



### MUGEN Gr. A CIVIC KEY HOLDER

90000-YZ7-0010  
W40mm x H35mm



### MUGEN EMBLEM GOLD

90000-YZ8-S001-G  
90000-YZ8-L001-G

(S) W120mm x H22mm  
(L) W161mm x H30mm

### F3 KEY HOLDER

90000-YZ7-0002

W40mm x H30mm 25g



### F3000 KEY HOLDER

9000-YZ7-0003

W40mm x H30mm 30g

F3000



### MUGEN EMBLEM RED

90000-YZ8-S001-R  
90000-YZ8-L001-R

(S) W120mm x H22mm  
(L) W161mm x H30mm



### MUGEN NEW EMBLEM STICKER

90000-YZ5-0041-S  
90000-YZ5-0041-L

6- (S) W200mm x H22mm  
7- (L) W300mm x H35mm



### MUGEN FORMULA STICKER TYPE A

90000-YZ5-0042-White  
90000-YZ5-0042-Black

(S) W75mm x H26mm  
7- (L) W150mm x H52mm



### MUGEN FORMULA STICKER TYPE B

90000-YZ5-0043-Black

(S) W300mm x H31mm

(L) W400mm x H42mm



### MUGEN FORMULA STICKER TYPE B

90000-YZ5-0043-White

(S) W300mm x H31mm

(L) W400mm x H42mm



### MUGEN SPIRIT STICKER

90000-YZ5-0044-S  
90000-YZ5-0044-L

150 (S) W80mm x H27mm  
200 (L) W130mm x H44mm



### MUGEN DOHC STICKER

90000-YZ25-0025-White  
90000-YZ25-0025-Gold

W394mm x H34mm



### MUGEN BODY STICKER

90000-YZ5-0039

W400mm x H42mm



### MUGEN WORKS EMBLEM

90000-YZ6-0008  
W120mm x H45mm



### Gr. A CIVIC BADGE

90000-YZ7-0004  
W42mm x H15mm



### F-3 ENGINE BADGE

90000-YZ7-0006  
W40mm x H30mm



### F-3000 ENGINE BADGE

90000-YZ7-0005  
W40mm x H30mm



### MUGEN SYMBOL FLAG

90000-YZ6-0007  
W90mm x H80mm





## WOLF NOSE BRAS

One trip behind a gravel truck is all that it takes to become a true believer in nose bras. Wolf produces what we feel is the state-of-the-art in nose protection. Each nose bra is custom-made for every application to ensure precise fit. Other features include screens that cover air intakes, grills and signal lights and the use of 16 gauge vinyl for extra protection from chips and scratches.

## WOLF EVOLUTION III CAR COVERS

Protect your investment with a Wolf Evolution III Car Cover. Each car cover is custom fit for the specific application and is constructed using the latest 4-layer Evolution III material. This material is highly water repellent, yet breathable to relieve heat and trapped moisture. All covers use the highest grade of bungee elastic to assure a snug fit.

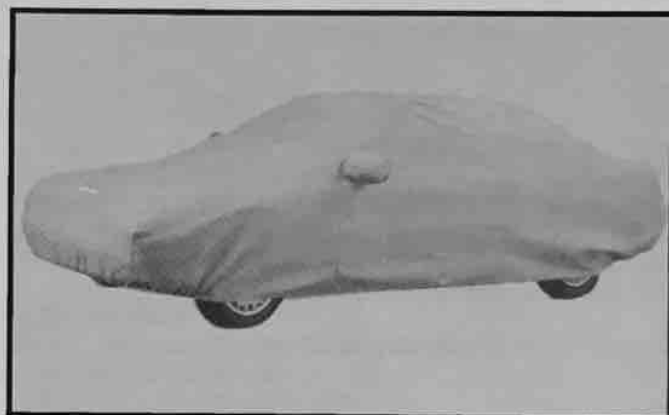

### APPLICATION LIST - BRAS & COVERS

Integra . . . . .	86-89	NS-X . . . . .	91	Civic . . . . .	88-91
Integra . . . . .	90-91	Accord . . . . .	76-81	CRX . . . . .	84-87
Legend Coupe . . . . .	87-90	Accord . . . . .	82-85	CRX . . . . .	88-91
Legend Coupe . . . . .	91	Accord . . . . .	86-89	Prelude . . . . .	81-82
Legend Sedan . . . . .	86-90	Accord . . . . .	90-91	Prelude . . . . .	83-87
Legend Sedan . . . . .	91	Civic . . . . .	84-87	Prelude . . . . .	88-91

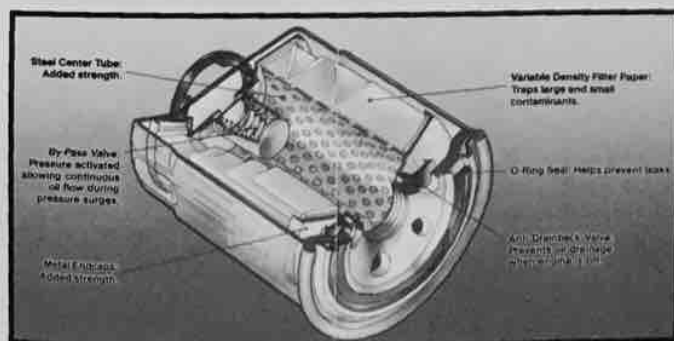

## OEM HONDA OIL FILTERS

If you are like most Honda enthusiasts, regular and frequent oil changes are routine. So why buy an "off brand" oil filter? Honda oil filters are superior to all other brands. Honda oil filters feature the correct pressure relief valves to protect your engine in the first crucial moments during cold starts. They also provide better filtration with larger surface area for longer effective life. Buy one and save, buy in a case lot and save even more.

Available for all Honda and Acura automobiles.



## RED LINE OIL

For many years King Motorsports used 50 weight petroleum-based racing oils in our engines, and were quite happy with their performance. We were urged to test Red Line Oil, and were skeptical at first. What we have discovered after two long racing seasons is that Red Line Oil lives up to every claim made by its manufacturers. We have seen a reduction in camshaft and rocker-arm wear, and main and rod bearings come out of the engine looking fresh, with no scoring or flaking. When oil temperatures reach 280 degrees and water temperatures hit 240 degrees, Red Line has protected against total engine failure. Why does Red Line lubricate better than other oils? According to the technical director

of Red Line, one of the keys is the adaptation of jet turbine lubricants to perform in automobiles. Red Line utilizes neo-pentyl polyol ester base stocks in all their projects, which are the only base stocks which can adequately lubricate in the intense heat of modern jet engines. Although the average oil temperature which a race car sees is considerably lower than those seen in jet engines, the temperatures in high-pressure contact zones such as bearings, cams, and lifters may see temperatures of up to 200 degrees Fahrenheit above the oil sump temperatures. The upper ring area sees temperatures in the range of 600 degrees Fahrenheit. At these temperatures petroleum oils no longer have adequate lubricating properties. A good synthetic oil can properly lubricate at temperatures up to 700 degrees Fahrenheit. This ability to lubricate hot metal is especially important in hot-running, high-performance engines. The increased stability of Red Line Oils enables them to last substantially longer than petroleum-based oils. We must say we are completely impressed with these products and recommend them not only to racers, but to people who want to be assured of the very finest oil available.

**MOTOR OIL: 10/40  
20/50; RACING OIL: 30 weight, 40 weight  
TRANSMISSION OIL: MTL  
FUEL INJECTION CLEANER: SI-1**

## MUGEN FORMULA 337 OIL TREATMENT

Another technical breakthrough by Mugen is the Formula 337 Oil Treatment. This oil treatment is designed to actually smooth the surfaces of all the reciprocating parts in your engine. The major ingredient in Mugen Formula 337 is Molybdenum Di Thio Phosphate (Mo D.T.P.) a friction modifier chemical compound. The two main features of Mo D.T.P. are its strong adhesion and quick dispersion through your engine. Because Mugen Formula 337 reduces internal friction, your engine will become more efficient with improved fuel economy. Mugen Formula 337 is very effective during your engine's critical break-in period. Also excellent results have been achieved by engines upgraded through the use of Mugen Formula 337.



## KMS/MUGEN POWER LICENSE PLATE FRAME

Since your taillights are the only thing they'll see of your KMS equipped Honda or Acura you might as well let them know why.

## ORDERING INFORMATION

### HOURS

King Motorsports is open Monday through Friday from 9:00 a.m. to 5:00 p.m. Central Standard Time. Often we are at the shop after hours and weekends, if we are at the phone we will gladly answer it and help you in any way we can.

### ORDERING PROCEDURES

The easiest, most convenient way to order is by telephone. We accept VISA and MASTERCARD. C.O.D. orders require CASH or CERTIFIED CHECK, NO PERSONAL CHECKS will be accepted. No exceptions. Mail-in orders paid by personal checks will not be shipped until cleared by our bank (allow up to 14 days). When mailing in an order, please use the King Motorsports order form provided. If you don't have an order form please give us a complete description of the part and cost. Your mailing address (no P.O. Boxes), method of payment, *daytime* phone number, complete description of vehicle — year, model, standard or automatic, and VIN number.

### SHIPPING

King Motorsports uses UPS as our main carrier. UPS is the quickest, most economical way to ship. UPS has three ways to send your parcel: Standard Ground, 2nd Day Air, and Next Day Air. Please specify the way you would like your parcel to be sent. If not specified, all parcels will be sent standard ground service. Shipping times vary but are usually 3-7 working days to the East Coast, 5-7 working days to the West Coast, and 2-4 working days for the Mid-western states. All prices are F.O.B. and *do not* include shipping. All incurred shipping costs are the responsibility of the consumer. All items too large for UPS, such as fiberglass and exhaust systems are shipped by truck. Most orders taken before 2:00 p.m. (CST) are shipped the same day and at no extra cost. If, for any reason your order is returned to us as undeliverable (this includes not in on three delivery attempts, nonpayment and refusals) it will be "frozen" until delivery costs incurred have been paid.

### RETURNS

All returns must be authorized by King Motorsports within 30 days of the invoice date and must be sent prepaid — NO EXCEPTIONS. A 20% restocking charge will be assessed at our discretion depending on reason for return. All returned products must be in new, unused condition.

### SHIPPING ERRORS

If you have received an incorrect item due to our error, you must notify us within 15 days of the invoice date. We will then send a UPS "call tag" to pick up the product with no cost to you, and immediately ship the correct product to you. At this time we will bill your charge card for this product and upon receipt of the wrong product, credit your account.

### CLAIMS FOR DAMAGED SHIPMENTS

All products leave King Motorsports boxed correctly and are in undamaged condition. Upon receiving your shipment *inspect immediately* in the presence of the carrier. All damage claims are the sole liability of the carrier. King Motorsports is in no way responsible for damage incurred during shipping. All claims for damaged goods must be made with the carrier.

### BACK ORDERS

Because of the limited production of Mugen components availability cannot be guaranteed. In the event something on your order is temporarily out of stock, we will place that item on back order and try to notify you of an approximate shipping date. If you do not want an item back ordered, please notify us of this and we will gladly cancel back ordered items.

### WARNING—READ BEFORE PURCHASING

A vehicle modified by the use of competition parts may not meet the legal requirements for use on public roads. It is your responsibility to comply with federal, state and local laws prior to vehicle use on public roads. Use or installation of competition parts may also affect or eliminate your insurance coverage. It is your responsibility to determine any change in coverage.

Competition parts are sold "as is" without any warranty of any type. There is no warranty stated or implied due to the unusual stress placed on competition parts and our inability to monitor their modification, installation or use. The entire risk of quality, performance or defect is with you the buyer. Should any part prove defective, for any reason or under any circumstance, you the buyer and not the manufacturer, distributor or retailer assumes the entire cost of all necessary repair or service and any and all consequential damage, cost or charges or any other liability.



105 East Main Street  
Sullivan, WI 53178

Phone 414-593-2800      FAX 414-593-2627

©1994 KING MOTORSPORTS  
ALL RIGHTS RESERVED  
NO REPRODUCTION PERMITTED